

Stainless steel electric winch

Stainless steel electric winches

PRIMO INOX from 250 to 990 kg

Instruction manual..... **UK**

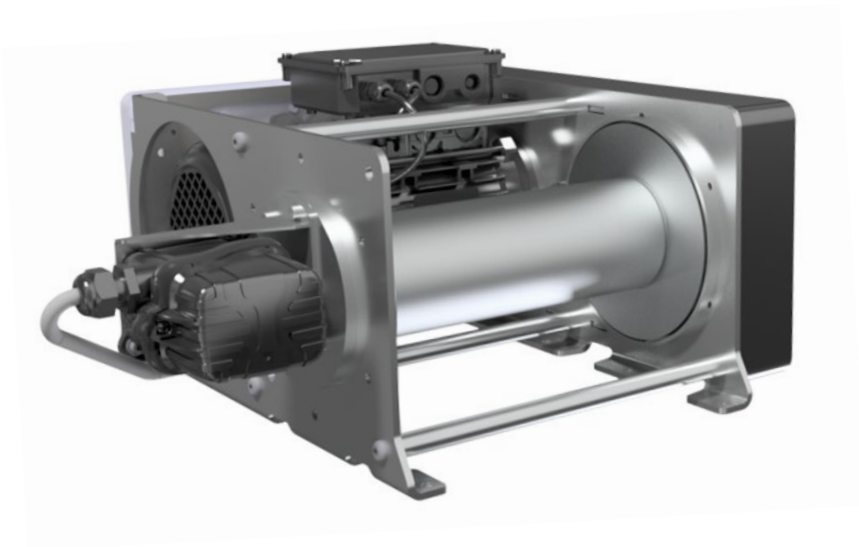

245-120.18.6

Summary

1 - Conditions for use.....	2
2 - Safety instructions	2
3 - Warranty.....	3
4 - Acceptance of the equipment.....	3
5 - Obligatory regulatory checks by the user	3
6 - Presentation of the machines.....	4
7 - Handling – Storage.....	6
8 - Installation and set-up.....	6
9 - Servicing and maintenance.....	10
10 - Taking out of use.....	11
11 - Spare parts.....	11
12 - Operating faults	11
13 - Declaration of EC conformity	12
14 - Appendices.....	12

1 - Conditions for use

All users must read the set-up instructions carefully before using the product for the first time. These instructions should enable the user to familiarise themselves with the winch and use it to its full capacity. The set-up instructions contain important information about how to use the winch safely and correctly. Compliance with these instructions helps to avoid danger, reduce repair costs, reduce stoppage time and improve the reliability and service life of the winch. The instruction manual must always be available in the place where the winch is being used. In addition to the set-up instructions and regulations concerning the prevention of accidents, the work safety and professional regulations in force in each country must also be respected.

This equipment is governed by European regulations and more specifically Directive 2006/42/EC on machinery, Directive CEM 2014/30/UE, BT 2014/35/UE and RED 2014/53/UE as well as the EN 14492/1 standard.

These winches are designed to move loads using a suitable steel rope. They have been designed to perform lifting and pulling operations within the defined load capacity limit and with safety factor $\underline{5}$ (static against sudden failure).

- For use in lifting, the European regulation makes certain equipment obligatory, such as a limit switch system and, for loads of 1,000 kg or more, a load limiter.
- The operator must check the presence of this equipment (available as an option from the manufacturer) before using the product for lifting purposes.
- The capacity indicated on the winch corresponds to the maximum capacity of use (MCU); in no event should this capacity be exceeded.
- **THIS WINCH MUST NOT, UNDER ANY CIRCUMSTANCES, BE USED TO LIFT PEOPLE.**
- Do not begin moving the load until you have attached it correctly and checked that all personnel are outside the danger zone.
- Before use, the operator must always check that the machine, rope, hook, markings and moorings are in good working order.
- The operator must check that the load is attached in such a way that the winch, the rope and the load place neither the operator nor any other person in danger.
- The winches can be used at ambient temperatures ranging from -10°C to +50°C. Please consult the manufacturer in the event of extreme conditions of use.

Important: In the event of an ambient temperature below 0°C, the brake must be tested to ensure that there are no operating faults resulting from the freezing conditions.

Use of winches requires strict compliance with the accident prevention and safety measures in force in the country.

The data concerning the resistance of the steel rope and its fastenings to heat must be available on request from the manufacturer and must be respected.

- HUCHEZ cannot accept any liability for the consequences resulting from the use or installation of equipment not provided for in the present instructions or for the consequences of disassembly, modifications or replacement of original parts or components with parts or components from other sources without the written agreement of HUCHEZ.

YOU MUST ALSO RESPECT THE REGULATIONS APPLICABLE IN YOUR COUNTRY.

2 – Safety instructions

Before using the equipment, check that there are no causes of overloading such as: adhesion to the ground, suction, jamming, etc. of the load.

As the operator of the winch, you are responsible for your own safety and the safety of your colleagues in the work zone of the machine.

The operator must respect all the following safety information, without exception, concerning the handling and operation of the winch as well as the references to other sections of this instruction manual. Failure to comply with these instructions increases the level of risk.

- Only the people designated by the company are authorised to operate the winch
- Before using the winch for the first time, familiarise yourself with its conditions of use. To this end, read the present instruction manual carefully and in its entirety and perform all the operations described herein one after the other.
- Inform your departmental manager or the safety officer of any malfunction so that the fault can be repaired immediately.
- Respect the directives of the industrial accident prevention organisations such as, in France, the Caisse d'Assurance Retraite et de la Santé au Travail (C.A.R.S.A.T.) and the Health and Safety Committee (HSC) of your company, if one exists.

- You must scrupulously respect the information in the sections concerning the CONDITIONS OF USE (below) and the WORK ROPE (page 10)
- The operator(s) must have an unimpeded view of the load.
- Please ensure that the operator is qualified to operate the machine in the conditions provided for in this manual. This will ensure the safety of both people and the environment.
- Do not lift or transport loads when there are personnel inside the danger zone.
- Do not authorise the personnel to walk under a suspended load.
- Do not leave a load suspended or with the rope taut unsupervised.

In addition to the above instructions, we must warn you against all incorrect use or handling listed below. It is dangerous and prohibited to:

- unwind the drum completely (retain 2 to 3 residual windings).
- pull at an angle.
- swing the load.
- use ropes with a diameter and texture which do not correspond to the specifications in the present manual.
- use damaged ropes or ropes with splices.
- grab or touch a moving rope or a rotating drum.
- use hooks without a latch, which do not correspond to the loads indicated on the winch or which are in poor condition.
- insert objects into moving parts.
- work on loaded winches or when the rope is taut
- use the winch rope as a towing chain.
- drum on the control box (overheating of the motor and electrical equipment).
- Place hands or clothes, etc. in contact with moving parts, in particular the areas where the rope is wound in/out.

3 - Warranty

Our electric winches are guaranteed for 2 years from the date of shipment (ex-works).
The seller undertakes to repair any operating fault resulting from a fault in the design, execution, components or materials themselves.

The warranty does not cover wear and tear or damage resulting from a lack of regular or periodic maintenance. It does not cover damage resulting from a lack of supervision, incorrect handling or an incorrect use of the machines, in particular overloading, pulling at an angle, under or overvoltage or incorrect connection.

The warranty does not apply to any disassembly, modification or replacement of mechanical or electrical parts undertaken without our agreement or by a non-approved operator. The warranty only applies to the manufacturer's original spare parts. During the warranty period, the seller must replace or repair any parts recognised as faulty after inspection by the qualified and approved department, all free of charge.

The warranty excludes all other services or compensation.

Repairs undertaken within the framework of the warranty are, in principle, performed in the seller's workshops or the workshop of a representative approved by the manufacturer. When work is carried out on the equipment outside of their workshops, the seller must cover the labour costs related to the disassembly or reassembly of these parts if these operations are performed exclusively by their personnel or a representative approved by the manufacturer. The parts replaced become the property of the seller and must be returned to them at their own expense.

In the case of components with a particular relative importance not manufactured by the seller themselves and which bear the brand of a specialist manufacturer, the warranty, which may vary according to the manufacturer, is the same as that agreed by this manufacturer.

4 – Acceptance of the equipment

Conduct a visual inspection of the packaging to ensure that it is in good condition.
In the event of an anomaly, issue the usual reserves.
Check that the winch corresponds to your order

5 –Obligatory regulatory checks by the user

This equipment has been designed to be tested:

- In a dynamic situation, with coefficient 1.1
- In a static situation, with coefficient 1.25

The users are required to comply with the standards in force in their country.

With regard to France:

Order of 1st March 2004 relating to the verification of lifting machines and accessories:

The modifications to the regulation relating to the use and verification of lifting machines and accessories, which came into effect on 1st April 2005, impose new obligations on all users:

- The suitability inspection that involves checking that the lifting machine is suitable for the work that the user intends to carry out, as well as for the risks to which workers are exposed, and that the intended operations are compatible with the conditions of use for the machine defined by the manufacturer.
- The assembly and installation inspection that involves ensuring that the lifting machine is assembled and installed in a safe way in accordance with the manufacturer's instruction manual,
- The general periodic visits that involve an inspection of the state of preservation and the operating tests.

- The commissioning or recommissioning inspections in the event of a change in the place of use, the configuration or the conditions of use on the same site; following the disassembly and subsequent reassembly of the lifting machine; after any major replacement, repair or transformation concerning the essential components of the lifting machine; following any accident caused by the failure of an essential component of the lifting machine.
- The maintenance booklet (order of 2nd March 2004 applicable from 1st April 2005) which must be used to record the maintenance operations carried out in accordance with the recommendations of the manufacturer of the machine as well as any other inspection, maintenance operation, repair, replacement or modification carried out on the machine. For each operation, it is essential to record the date of the work, the names of the people and, where appropriate, the companies which carried out the work, the nature of the operation and, if it is a periodic operation, the frequency. If the operations involve the replacement of certain components of the machine, the references of these components are indicated. The English version of the maintenance booklet for our lifting winches can be downloaded from our website www.huchez.fr/uk under the heading "After sales services". A copy is however proposed in the annexes of this manual.

The inspections must be carried out in accordance with a protocol and are intended to ensure preventive maintenance aimed at detecting any damage or defect liable to cause a hazard.

6 – Presentation of the machines

6.1 - General

These winches are intended for pulling or lifting loads weighing a maximum of 250 to 990 kg:

- . Electric winches, IP 54.
- . Rigid stainless steel structure
- . Mechanically welded stainless steel drum with wide flanges for safe and sound fastening of the rope.
- . 230 volt with permanent capacitor – 50 Hz single-phase lifting-type self-braking motor. P = 0.75 kW or 1,1 kW according to the models – Class F – IP 66.
- . 230/400 volt, 50 Hz three-phase lifting-type self-braking motor. P = 0.75 kW, 1,1 kW or 2,2 kW according to the models – Class F – IP 66.
- . Watertight reducer in oil bath with helical gears
- . The FEM category is 1Bm (ISO : M3).
- . Electrical equipment under watertight cover.
- . Electric control box IP66.
- . Very low voltage, 24 V remote control, IP 66 with industrial connector IP 66.
- . Emergency stop as standard
- . The limit switch is standard and IP 66.
- . Marine type electric cable (without halogen).
- . 3-button control box (Up – Down – Emergency stop) with detachable cable (3 m control cable), IP 66.

6.2 - Dimensions

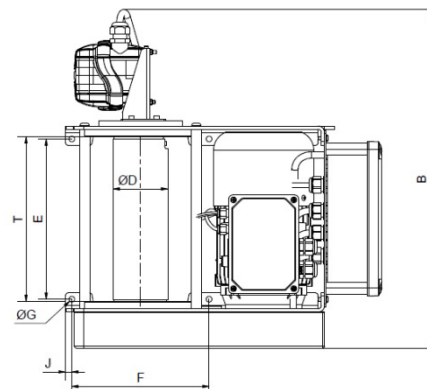
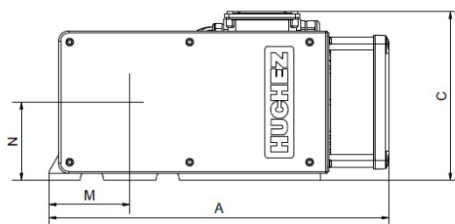
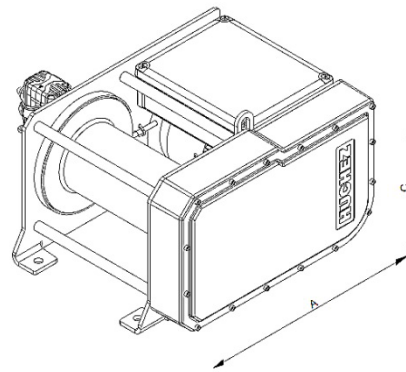
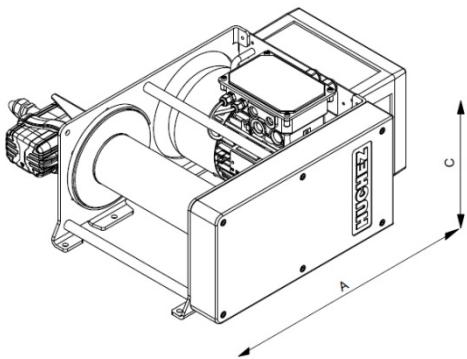

Models	PRIMO INOX BT 250 & 400	PRIMO INOX BT 990
A mm	495	580
B mm	528	615
C mm	244	326
ØD mm	85	140
E mm	250	260
F mm	214	280
ØG mm	9	17
J mm	10	30
M mm	117	170
N mm	113	171
T mm	257	280

6.3 – Models available

References	PRIMO INOX BT 251	PRIMO INOX BT 253	PRIMO INOX BT 401	PRIMO INOX BT 403	PRIMO INOX BT 991	PRIMO INOX BT 993
Capacity on the 1st layer kg	300	300	400	400	990	990
Capacity on the last layer (kg)	250	250	400	400	990	990
Nb of layers	4	4	3	3	2	3
Wire rope capacity at the 1st layer m *	13	13	11	11	11	11
Max. rope capacity (m)	63	63	39	39	20	42
Rope diameter (mm)	5	5	6	6	10	10
Speed on the 1st layer m/min	7.7	7.7	6.2	6.2	4	4
Speed on the last layer (m/min)	10.3	10.3	8	8	4.2	5.2
FEM	1Bm	1Bm	1Bm	1Bm	1Bm	1Bm
Motor (kW)	0.75	0.75	0.75	0.75	1.1	1.1
Supply	1 Ph -230 V	3 Ph-230/400 V	1 Ph - 230 V	3 Ph - 230/400 V	1 Ph - 230 V	3 Ph -230/400 V
Weight (winch without wire rope) kg	40	40	40	40	90	90

Important: the diameter of the rope indicated above corresponds to the rope recommended in the FEM 1 Bm / ISO M3 classification. It also corresponds to the capacity on the last layer.

Important: it is obligatory to check that the rope resistance coefficient complies with the load lifted (FEM 1 Bm / ISO M3)

6.4 - Options

These winches can be supplied, optionally, with:

- Rope press roller
- Grooved drum

6.5- FEM classification

There are eight groups of mechanisms:

FEM	1 Dm	1 Cm	1 Bm	1 Am	2m	3m	4m	5m
ISO	M 1	M 2	M 3	M 4	M 5	M 6	M 7	M 8

To determine the group for a lifting machine, winch or hoist, three essential parameters must be considered:

The maximum load to be lifted

Including the weight of the rope and any lifting accessories present (hook etc.), except if they have a total weight less than or equal to 5% of the load to be lifted.

The usage rate

Indicates the extent to which the lifting machine is used at maximum load or with a reduced load. There are four different usage rates:

Light	Lifting machines rarely subject to maximum load and regularly used for very light loads.	$k \leq 0,5$
Medium	Lifting machines quite often subject to maximum load and regularly used for light loads.	$0,5 < k \leq 0,63$
Heavy	Lifting machines often subject to maximum load and regularly used for medium loads.	$0,63 < k \leq 0,8$
Very heavy	Lifting machines regularly subject to loads close to the maximum load.	$0,8 < k \leq 1$

For an exact classification, it is preferable to calculate the average cubic value using the following formula:

$$k = \sqrt[3]{(\beta_1 + \gamma)^3 \cdot t_1 + (\beta_2 + \gamma)^3 \cdot t_2 + \dots + \gamma^3 \cdot t_\Delta}$$

where:

$\beta = \frac{\text{payload or partial load}}{\text{rated capacity}}$	$t = \frac{\text{operating time with payload or partial load} + \text{dead load}}{\text{total operating time}}$
$\gamma = \frac{\text{dead load}}{\text{maximum capacity}}$	$t_\Delta = \frac{\text{operating time with dead load only}}{\text{total operating time}}$

FEM classification

Usage rate	PRIMO INOX 250 / 400 / 990			
	Average operating time per day in hours.			
	15'	30'	1 h	2 h
Light	1Dm	1Dm	1Cm	1Bm
Medium	1Dm	1Cm	1Bm	1Am
Heavy	1Cm	1Bm	1Am	2m
Very heavy	1Bm	1Am	2m	3m

7 – Handling - Storage

Important: the angle formed between the hook and the two sling points must not exceed 45°. Lift and place the winch carefully without dropping it.

Do not forget that the centre of gravity of the winch is off-centre.

For more information concerning the weight of the winch, please consult the Technical specifications chapter.

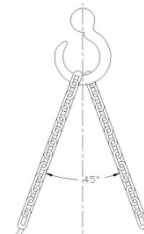

When stored, these winches must be protected from bad weather in a clean and dry place at a temperature between -10°C and +50°C.

8 - Installation and set-up

8.1 Installation

The service life of a winch depends on its installation and set-up.

It is essential that you read this manual carefully before installing, using and servicing your machine.

Any use which contravenes our instructions may create a hazard. In this case, the manufacturer cannot accept any liability.

- Do not use this machine before having read and understood the instruction manual in its entirety
- Always keep the manual close to the machine, available to the operator and the maintenance officer
- Comply and ensure compliance with the safety rules

Connect to the power supply (see 8.3 Power supply)

Check the rope and hook

Ensure you are ready to press the emergency stop button at all times, with no load attached, then check that the movement of the hook corresponds to the direction of the arrows indicated on the control unit.

Check that the brake works: with a nominal load attached, lift the load and lower it again or, in the case of pulling, pull this load.

Check that the limit switch works.

The winch has been subjected to dynamic and static tests in the factory (cf. Test record).

8.2 Place of installation

These winches must be installed and bolted to a flat, solid and secure surface capable of bearing the loads to which it will be subjected. An unsuitable installation site may lead to serious accidents.

To assess the suitability of the place of installation and its resistance to loads, you must take into account any possible overloading, the weight of the winch itself and the weight of the options and/or accessories fitted to it, including all dynamic forces. The winch user is responsible for determining the place of installation. If in doubt with regard to the suitability of a place of installation, contact a civil engineer or a statics specialist.

Tighten the clamping bolts correctly

Bolt / nut	Stainless steel screw / nut tightening torque class 70 N.m
M8	17
M16	140

8.3 – Rope outlets

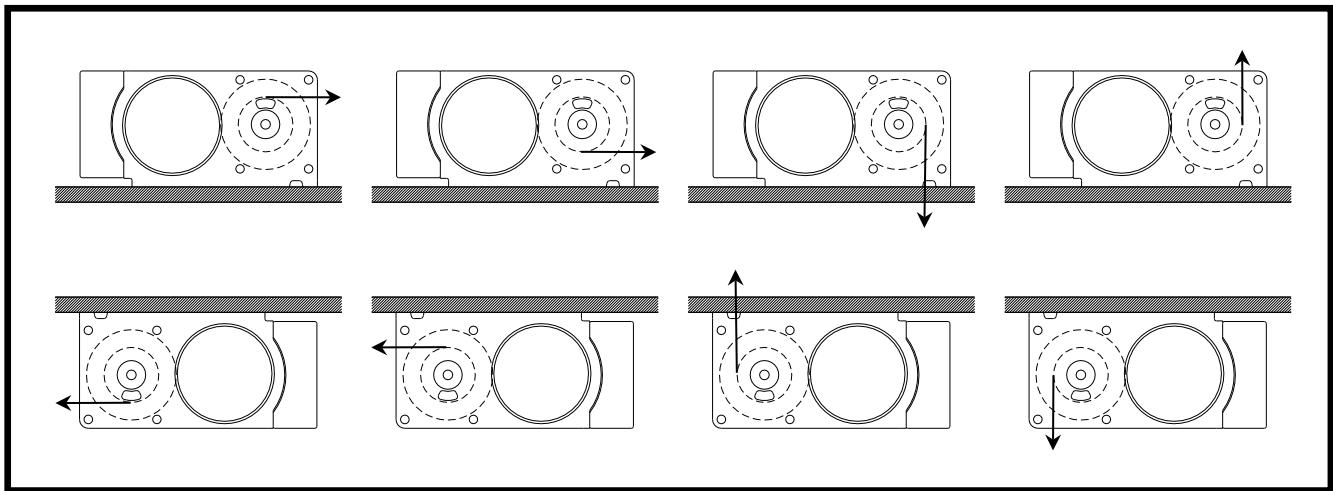

8.4 – Power supply

Before undertaking any operation on the electrical unit, check that the power supply to the machine is off. A disconnecting switch must be placed no more than 10 metres from the place of use.

Very important: the winch will only provide full power if the motor is supplied via a cable section which is perfectly suited to this use. Provide protection for individuals in front of the electrical unit.

8.4.1 – Electrical connections

The power supply cable, the protective fuses and the main disconnecting switch (see wiring diagram) must be provided by the customer. Check that the supply network complies with the machine.

Check the type of current; there must not be more than about 5% deviation from the rated voltage
Neutralise electrical sources

Check that the main power supply switch on the winch is in the off position.

Do not connect the power supply cable to the machine using connection terminals (split fittings etc.)

Do not use a cable with a smaller section to supply power to the machine. Power supply via a generator is possible:

- Minimum power of 3.75 kVA according to the models 250 and 400 kg.
- Minimum power of 5,5 kVA according to the models 990 kg.

Never "shunt" the disconnecting switches, electrical switches, prevention or limitation equipment.

Never block, adjust or remove switches or end stops in order to go beyond the levels that they allow.

A disconnecting switch must be placed no more than 10 metres from the place of use. Recommended rope section:

VOLTAGE	TENSION	TYPE	Length of supply rope	
			10 m	30 m
230 V single phase	230 V mono	2 + T	2.5 mm ²	4 mm ²
230 V three phase	230 V tri	3 + T	4 mm ²	4 mm ²
400 V three phase	400 V tri	3 + T	2.5 mm ²	2.5 mm ²

8.4.2 – Connection

Connect the power supply using the single phase or three phase male connector supplied using about 0.5 m of power supply cable. Check that the winch works (direction of rotation)

- Do not change the direction labels in the control unit or in the winch's internal wiring.

8.5 – Work rope

Important: the direction of rotation of the drum depends on the way in which the machine is connected (order of the three-phase current phases)
Reminder: check the maximum capacity of the winch

Very important:

The safety regulations require that 2 to 3 coils of rope always be left on the drum.

To comply with the legislation, the rope diameter must not exceed the recommended diameter.

If the rope and the hook used were not supplied with the machine by the manufacturer, check that they guarantee a level of safety corresponding to table § 6.5.

When the winch is supplied with the rope wound on, it has not been tautened during assembly.

The user must tauten the rope using a minimum force of 1% of the operating load of the winch.

The service life of the steel ropes used on the winch depends on a number of factors, including the form of the work cycles (lifting height, lifting speed, number and type of deviations, etc.) and the operating mode (number of coil layers, distribution of the work cycles over the length of the steel rope, etc.). The service life of steel ropes is therefore subject to considerable variation depending on these factors.

Please remember that rope must be replaced with equipment which meets the same specifications as the original rope.

This replacement must be recorded in the maintenance booklet.

IMPORTANT: even if the rope was supplied with the winch, it was not tautened during assembly. The user must tauten it using a minimum force of 1% of its breaking load.

Measuring the rope diameter using sleeve callipers:

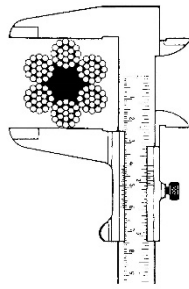

Correct measurement

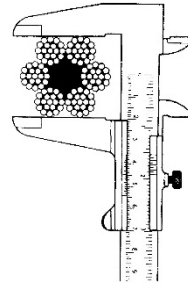

Incorrect measurement

Handling steel ropes

- Always use suitable protective gloves when handling steel ropes
- Never use a rope with faults such as:
 - ✓ An unacceptable number of broken strands
 - ✓ Basket distortions
 - ✓ Broken bird-caging
 - ✓ Flattening
 - ✓ Constrictions
 - ✓ Strand extrusions
 - ✓ Broken rope cores
 - ✓ Slack strands
 - ✓ Bends or loops
- Always check the level of wear of the rope before use
- Never use steel ropes as loops
- Never expose steel ropes to angular or sharp edges



Unwinding the rope from its reel:

CORRECT :

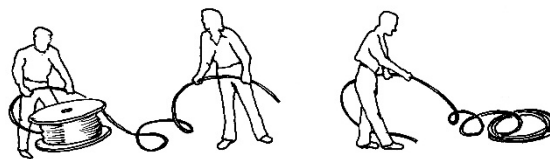
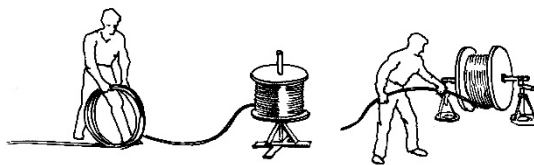

INCORRECT

Fastening the rope

Models PRIMO INOX 250/400/990

Refer to the photos below.

- If necessary, remove the limit switch
- Slacken the screws
- Insert the end of the rope between the drum flange and the cable clamp
- Tighten the screws
- Check that the rope is securely clamped
- Reassemble the limit switch

The rope should never form a loop.

Important: the direction of rotation of the drum depends on how the machine is connected.

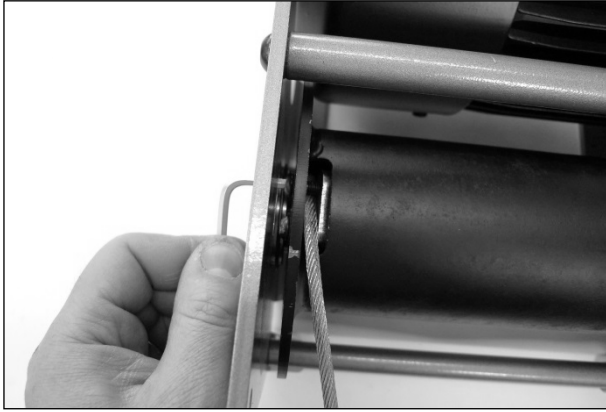

Winding the rope on the drum

To do this, tauten the rope and wind it with joined strands onto the drum.

Very important : The safety regulations require that 3 coils of rope always be left on the drum. If the rope and the hook used were not supplied with the machine by the manufacturer, check that they guarantee a level of safety corresponding to table § 5.

Start to wind the rope forming a spiral to the right. In order to facilitate this operation, some drums are provided with a heel attached to one of the flanges, which "fills" the space between the first turn and the flange.

The first layer must be wound in a compact manner and under tension. Take a mallet or a block of wood and knock the turns against one another; not too hard to prevent the strands from overlapping one another, but tightly enough to prevent the rope from moving on the drum. If the first layer is wound too loose, the next layer will form a space in the first layer that will result in an open area. If the first layer is too tight, the subsequent layers will not have enough space between turns.

In any case, the first layer and all the other layers must be wound onto the drum with enough pre-tension (5-10 % of the MWL of the rope). If the rope is wound without any tension, it will suffer from crushing and premature flattening caused by the loaded upper layers.

Even if the first layer is wound correctly during installation, it will expand a little while in service. When the first layer expands (loss of pre-tension) the initial procedure **MUST** be performed at regular intervals.

Otherwise, the "hard" turns will severely crush the base layers.

Whatever you do, **DO NOT** pass the rope through a clamping mechanism. For example, two blocks of wood screwed together. **THIS WILL CAUSE IRREPARABLE DAMAGE TO THE ROPE!**

It is important to respect the indication below; if the rope start on the winch is at the bottom, respect the same principle. Failure to respect this precaution will damage your rope irretrievably and it will become extremely dangerous.

Check the direction of cable winding according to the motor connection.

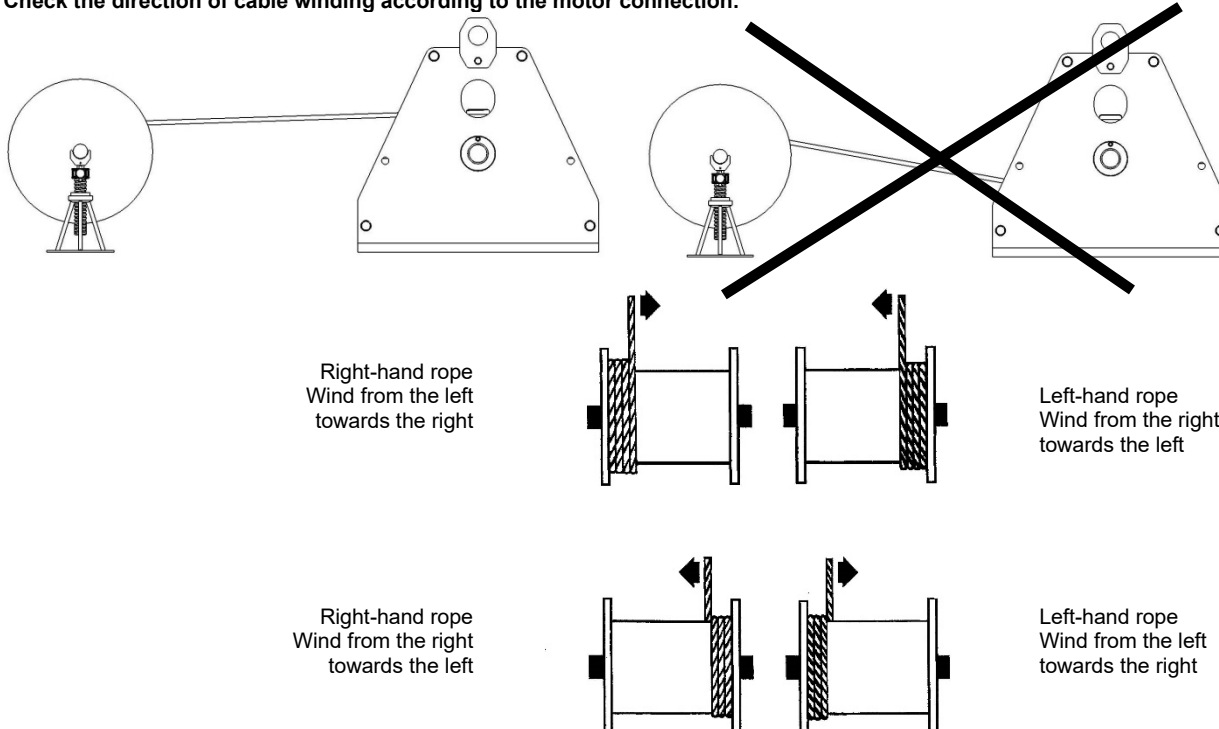

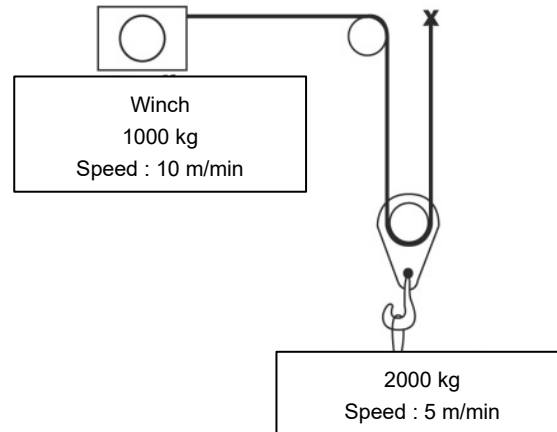
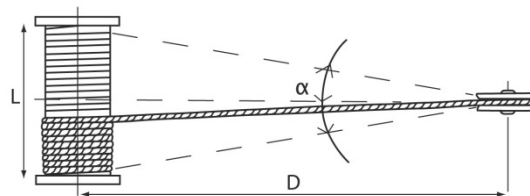
Reeving principle :**Deflection angle :**

Smooth drum : $\alpha = 1,5^\circ$ max
 Grooved drum : $\alpha = 2^\circ$ max
 $D = 20 \times L$

9 – Servicing and maintenance

Respect the following instructions, in particular if your winch is used in a large number of different locations or in a particularly dirty and damp environment:

- Remove the bulk of the dirt from the winch.
- Always store the winch in a dry, clean place.

9.1 Before starting up

Check:

- The electrical connections are in good working order.
- The rope is correctly fastened to the drum.
- The exterior appearance of the winch.

9.2 When using for the first time

At the start of the installation process, it is recommended that you respect a running-in period of thirty hours at $\frac{3}{4}$ of the load. The nominal capacity will be obtained after this running-in period.

9.3 Periodic servicing

See also chapter 5: Obligatory regulatory checks by the user

Every 50 hours, check the lubrication.

Every 100 hours, change the grease.

The reducer is lubricated using RENOLIT CXI 2 (fabricant : FUCHS).

Very important:

In the event of a change in the type of grease, contact our after-sales service.

Winches

Remove the bulk of the dirt from the winch.

Always store the winch in a dry place

Ropes

The ropes must be cleaned and greased regularly using a special grease which penetrates to the rope core.

Only use appropriate and harmless cleaning products for all the components of the rope, including the core.

If lubrication is impossible for usage-related reasons, the service life of the rope will be reduced considerably and increased monitoring of the rope will therefore be necessary.

The ropes must be checked visually every day.

Servicing and maintenance operations on the winch and rope must be carried out without any load on the winch.

Hooks

Check the hook and its safety latch

If the rope and hook are not supplied by the manufacturer, check that the parts used guarantee a level of safety corresponding to table §4.4.

Check the fastening points of the reeving on a regular basis.

Brake

Models PRIMO INOX 250/400/990
(the brake is located inside the motor)

. Operating principle:

On starting the motor, the internal magnetic field opens the brake by lifting the conical plate from the friction surface at the bottom of the motor.

On stopping the motor, the magnetic field disappears. The central spring closes the brake again by bringing the conical panel back into contact with the motor's rear flange.

10 – Taking out of use

If the equipment is in a state of disrepair likely to give rise to risks, the user is obliged to ensure that this equipment is eliminated, i.e.: prevented from operating and possibly disassembled.

11 – Spare parts

If during maintenance operations you notice that certain parts of your winch need to be replaced, use HUCHEZ original parts only.

For all spare parts orders, please indicate the following specifications on your order

- The type and capacity of the winch (indicated on the nameplate).
- The serial number and year of manufacture (indicated on the nameplate).
- The number or designation of the desired parts (exploded view).

12 – Operating faults

Fault	Possible cause	Solution
Motor does not start.	Power supply cut.	Check and correct the problem Check the emergency stop.
	Brake not released	See "brake fault"
	The contactor does not respond, Control fault.	Check the contactor control and eliminate the fault.
	Limit switch engaged.	Check the limit switch.
Motor does not start or starts with difficulty.	The voltage or frequency varies considerably compared to the setting when starting.	Improve the mains conditions. Check the cable sections.
Motor revs and absorbs a lot of current.	Brake not released.	See "brake fault"
	Faulty winding.	Take the motor to an approved workshop for repair.
	One supply phase missing.	Check the power supply.
Circuit breaker activated instantly.	Short circuit in the power supply cables.	Eliminate the short circuit.
	Short circuit in the motor.	Have the fault corrected in an approved workshop.
	Power supply cables incorrectly connected.	Correct the connection.
	Motor earth fault.	Have the fault corrected in an approved workshop.
Speed greatly reduced when loaded.	Voltage drop.	Increase the power supply cable section.
Motor overheated (temperature measurement)	Insufficient ventilation.	Clear the ventilation lanes.
	Ambient temperature too high.	Respect the authorised temperature range.
	Bad contact in the power supply cable (operates temporarily on 2 phases)	Eliminate the bad contact.
	Circuit breaker activated.	Bad contact in the relays.
Drive system too noisy	Service factor exceeded (S1 to S10, DIN 57530), e.g. because start speed is too high.	Adapt the service factor to the prescribed conditions; if necessary, call a specialist to determine the type of motor.
	Rotating parts vibrate.	Check the balances, eliminate the cause of the vibrations.
Brake not released.	Foreign bodies in the ventilation lanes.	Clean the ventilation lanes.
	Max. air gap exceeded due to worn lagging.	Take the motor to an approved workshop for repair.
Motor does not brake.	Incorrect air gap.	Take the motor to an approved workshop for repair.
	Brake lagging totally worn.	Take the motor to an approved workshop for repair.

PRIMO INOX 250, 400 and 990 kg

250 / 400

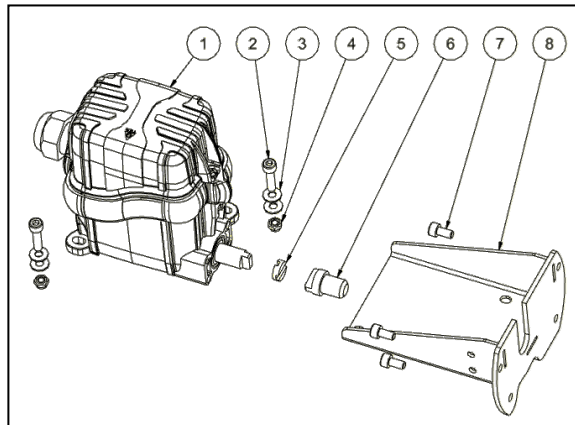

990

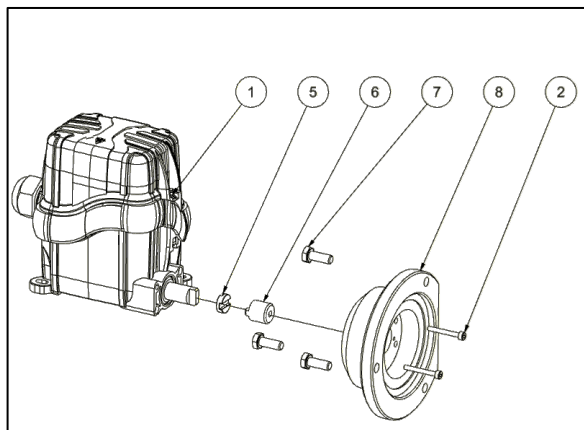

No	PRIMO INOX 250 / 400		PRIMO INOX 990		Description
	Qty	Part no.	Qty	Part no.	
1	1	24696	1	24697	Limit switch
2	2	13124	2	13495I	Limit switch fixing screw
3	4	13208			Washer
4	2	13351			Brake nut
5	1	24694	1	24694	Oldham disk
6	1	24690	1	24762	Limit switch end
7	4	13614I	3	13058I	Support fixing screw
8	1	24673	1	24755	Limit switch support

PRIMO INOX 250/400 kg – Part references

THE SERIAL NUMBER MUST BE SPECIFIED FOR ALL SPARE PART ORDERS.

No	Qty	PRIMO INOX 251	PRIMO INOX 253	PRIMO INOX 401	PRIMO INOX 403	Description
		Part no.	Part no.	Part no.	Part no.	
1	2	3083	3083	3083	3083	Bearing 6003
2	2	3642I	3642I	3642I	3642I	Bearing 6205 2RS STAINLESS STEEL
3	4	13131	13131	13131	13131	Screw CHC M6x16
4	3	13257	13257	13257	13257	Screw TFHC M6x12
5	1	13434	13434	13434	13434	Ring 7103-28
6	3	13442I	13442I	13442I	13442I	Screw CHC M6x55 STAINLESS STEEL
7	3	13687I	13687I	13687I	13687I	Screw CHC M6x45 STAINLESS STEEL
8	3	13688	13688	13688	13688	Screw TBHC M8x16
9	1	23777	23777	23777	23777	Neoprene joint Ø4
10	1	24650	24650	24650	24650	Welded reducing flange
11	1	24654	24654	24654	24654	Welded outer flange
12	1	24657	24657	24657	24657	Transmission casing
13	1	24658	24658	24658	24658	Sub-unit drum
14	3	24664	24664	24664	24664	Tie Rod
15	1	24665	24665	24665	24665	Drum bearing housing
16	1	24666	24666	24666	24666	Intermediate bearing housing
17	1	24667	24667	24667	24667	Bearing stop panel
18	1	24668	24668	24668	24668	Train wheel 1-2
19	1	24677	24677	24669	24669	Train sprocket wheel 2-2
20	1	24670	24670	24670	24670	Intermediate shaft
21	3	24671	24671	24671	24671	Tapped head screw
22	1	24692	24693	24692	24693	0.75 kW motor brake
23	1	24695	24695	55451	55451	Train wheel 2-2
24	1					AE BT PRIMO 250-400 STAINLESS STEEL
25	1					SUB-UNIT LIMIT SWITCH PRIMO INOX 250-400

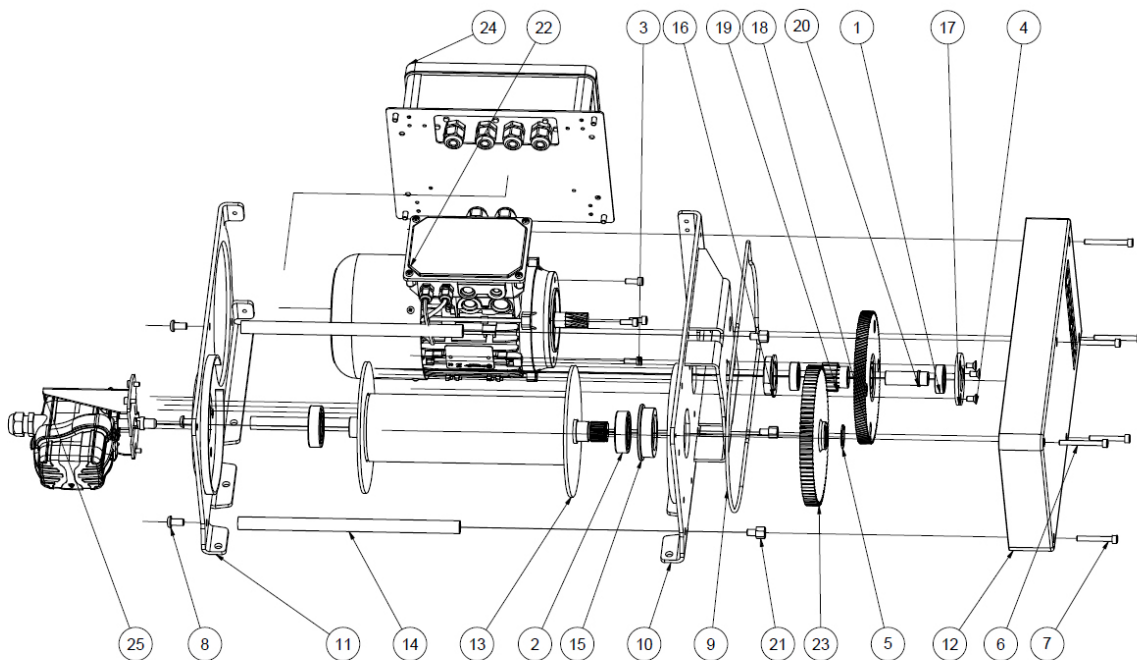

PRIMO INOX 990 kg – Part references

THE SERIAL NUMBER MUST BE SPECIFIED FOR ALL SPARE PART ORDERS.

PRIMO INOX 990 kg

No.	Qty	Part no.	Description	No.	Qty	Part no.	Description
1	1	2510	Bearing 6004 2RS NR	22	1	24716/17*	Motor 1.1kW (IEC80)
2	1	2564i	Bearing 6210 2RS STAINLESS STEEL	23	1	24721	Mounted bearing panel
3	1	2880	Bearing 6205 2RS NR	24	1	24725	Reduction gear case Primo 1T
4	1	3324	Bearing 6306 2RS	25	1	24728	Feed wheel 1
5	1	2926	Nitrile joint foam Ø8	26	1	24731	Feed wheel 2
6	1	2964	Bearing 6003 2RS RN	27	1	24734	Feed wheel 3
7	1	3083	Bearing 6003 2RS	28	1	24737	75-tooth sprocket wheel
8	1	3324i	Bearing 6306 2RS STAINLESS STEEL	29	1	24750	Stainless steel reduction gear flank
9	4	13011	Lock nut M6	30	1	24751	Stainless steel limit switch flank
10	1	13041	Bearing 6004 2RS	31	1	24752	Stainless sub-unit drum
11	2	13057i	Screw TH M6 x 12 STAINLESS STEEL	32	4	24753	Stainless steel tie rod
12	8	13075i	Screw TH M10 x 25 STAINLESS STEEL	33	1	24754	Stainless steel case closing panel
13	1	13131	Screw CHC M6x16	34	1	24757	Stainless steel hoisting hook
14	6	13209i	Washer M Ø6 STAINLESS STEEL	35	1	24758	Bearing housing 1 stainless steel
15	1	13218	Washer	36	1	24759	Bearing housing 2 stainless steel
16	16	13255i	Screw CHC M6x90 STAINLESS STEEL	37	1	24760	Bearing housing 3 stainless steel
17	8	13306i	Washer M Ø10 STAINLESS STEEL	38	1	24761	Bearing housing 4 stainless steel
18	4	13541	Screw TFHC M6x20	39	1	24763	Motor sprocket wheel
19	1	13625	Screw TH M16-30	40	1	24718	Split stop ring 2-20 Stainless steel
20	4	13675	Shoulder screw M6x10	41	1		AE Primo 1t stainless steel SUB-UNIT LIMIT SWITCH PRIMO 990 kg STAINLESS STEEL
21	1	22795	Washer 16x65x5	42	1		

*24716: 1ph~ 230V / 24717: 3ph~ 400V

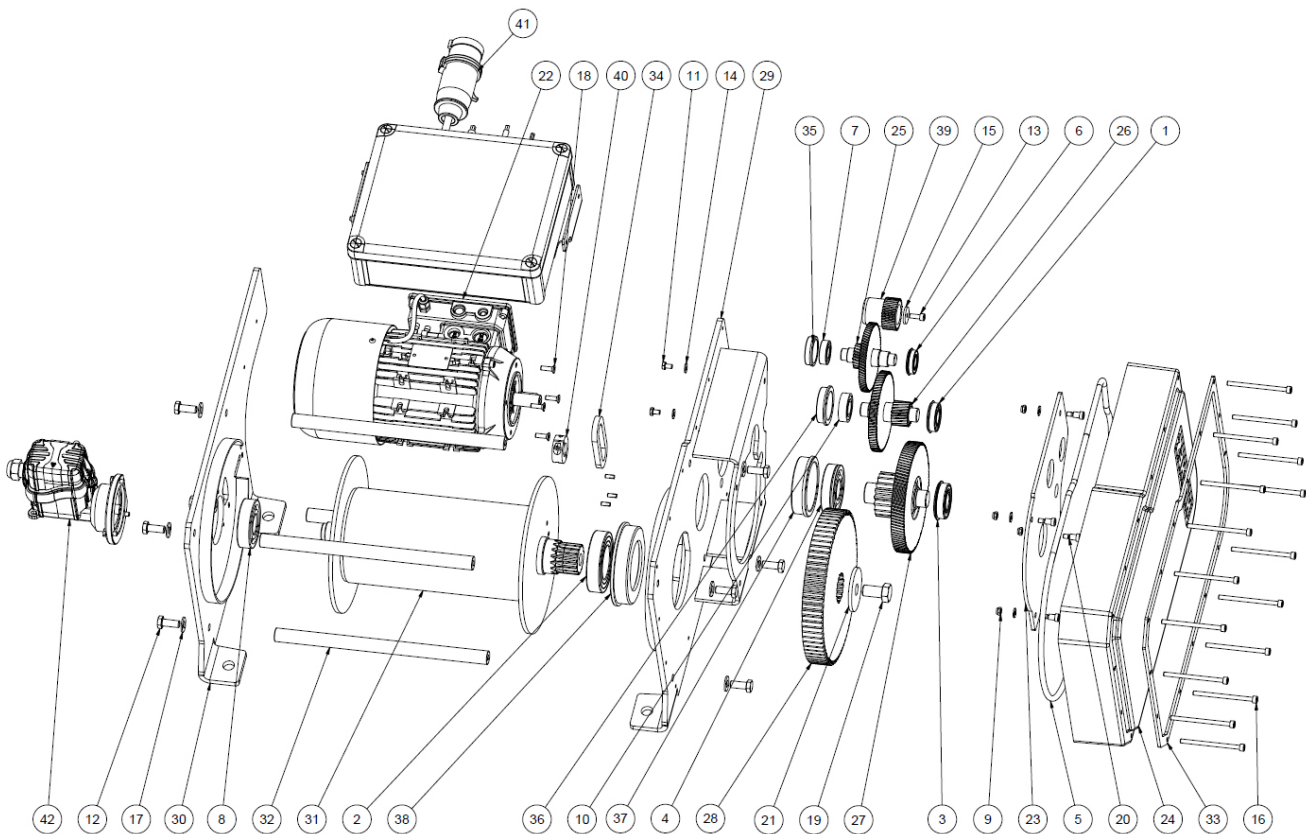

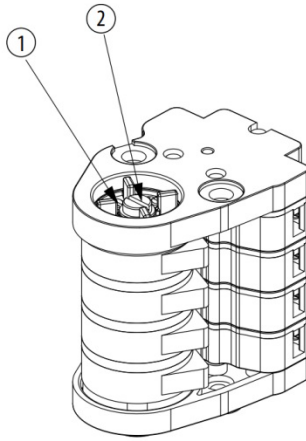

Before doing anything, turn off the main power supply to the winch.

To set the cams properly, loosen the central screw ② of the group of cams. Then set the trigger point for each cam using their adjustment screws ①. The screws are numbered to indicate the cams in increasing order from the bottom of the group to the top. Retighten the central screw.



The English version of the maintenance booklet for our lifting winches can be downloaded from our website www.huchez.fr/uk under the heading "After sales services".

Date	Person In charge Company	Name	Nature of the operation	References of replaced parts	Frequency if appropriate	Signature

Huchez© 2012

